



MOLYKOTE[®]
FROM DOW CORNING

Long-life Lubricants for Brake Systems



Driving technology and service for worldwide performance.

Long-life lubricants for demanding brake systems

The right lubricant can mean the difference between whether a moving part performs or fails. That's why it's especially critical to choose the right lubricant for a brake system.

Dow Corning offers a complete line of both general-purpose and specialty lubricants. Many are high-performance lubricants especially designed for automotive brake system applications. They go beyond the capabilities of conventional oils and greases to:

- reduce noise
- achieve long-life lubrication
- reduce fretting wear
- reduce stiction
- withstand extreme conditions
- reduce judder

Our lubricants are designed to keep working under extremes of load, speed, and temperature. They hold up even in the most difficult environments where exposure to water, dust, or corrosive chemicals might attack and degrade ordinary lubricants. They also offer good compatibility with elastomers commonly used in automotive brake systems, such as EPDM and neoprene.

You can expect our lubricants to provide extended lubrication periods and reduced warranty and replacement costs. They can even provide maintenance-free, long-term lubrication in many applications.



AV04641

Products to meet your braking needs

You can select from our extensive line of *Dow Corning*[®], *Molykote*[®], and *Lubolid*[®] brand lubricants—both “wet” (e.g., greases) and “dry” (e.g., anti-friction coatings). They are formulated from a wide range of base oils, including silicone, polyalphaolefin, polyglycol, mineral oil, ester, and perfluoropolyether. In addition, many of our lubricants incorporate solid additive technology.

Our multi-technology products come in five forms:

Greases. High-performance greases are designed for dynamic metal-to-metal, metal-to-rubber, metal-to-plastic and plastic-to-plastic applications.

Most greases are based on synthetic formulations that have excellent resistance to thermal degradation. Many are fortified with solid lubricant additive technology to provide effective lubrication under extreme load conditions.

High-performance fluorinated greases are designed for extended service at higher temperatures and higher loads, and in harsh chemical environments.

Compounds. Silicone compounds are greaselike lubricants that generally contain silicone fluids and inert silica fillers. They are resistant to oxidation while maintaining their properties over a wide temperature range. They're ideal as non-curing sealants or as release agents between metal and elastomeric materials.

Pastes. These lubricants have high concentrations of solid lubricants blended in various bases. They are used where a high concentration of solid lubricant is required, such as initial run-in and areas exposed to high loads.

Anti-Friction Coatings. In simple terms, anti-friction coatings can be thought of as lubricating paints. They typically contain a select blend of solid lubricants and a binder dispersed in a solvent carrier. After curing, the coating forms a dry lubricating film that can help prevent corrosion and is aesthetically pleasing.

Anti-friction coatings are ideal for applications involving dusty environments or for inaccessible areas containing parts that need long-term lubrication.

Lubricating Solids. These lubricants are primarily used as additives for plastics and friction lining formulations to improve wear resistance and control friction.

They offer good thermal stability and are resistant to wear.

Service and support from start to finish

Our global automotive centers feature a wide range of equipment for designing, prototyping, testing, and validating our lubricants and other materials in specific applications. We are able to work with you to evaluate and analyze material options, as well as provide samples or prototypes for validation and preliminary estimate of production usage rates.

You can rely on our people to help you select the right lubricant for your brake system application. But we don't stop there.

We think it's important that the lubrication process properly fits into your manufacturing scheme. To that end, we'll work with you to develop the right delivery system to apply our lubricants to your product. That means we can offer options beyond traditional drums and pails for specialized needs.



AV04645

It also means we can make recommendations for matching our lubricants to the best application equipment. We can even work with you and the equipment supplier(s) to help you put together the right process.

To learn more about how we make sure our products meet both your expectations and ours—as well as how they stack up against the competition—read on.



AV04646



AV06643

Our regional automotive centers, located in Germany, Japan, Korea, Brazil, and the U.S., have the people and equipment in place to meet your needs. We also have R&D facilities at our corporate headquarters in Midland, Michigan.

We conduct a variety of ASTM, DIN, ISO, and other standard tests at these facilities. The North American facility, for instance, features specialized test equipment such as a high frequency reciprocating tester, which enables us to simulate real-life duty cycles. It also helps us compare how well our lubricants stand up against those from other suppliers.

A comparison of stiction is shown in figure 4. Note the lower value for Molykote G-807 Low Friction Silicone Compound, compared with competitive PAG and conventional silicone products, indicates that the Molykote product will slide more smoothly over rubber, reducing stiction and resulting in longer brake life.

Figure 5 shows the effect of high frequency oscillation under load on lubricant breakdown and failure. Note that Molykote® G-407 Anti-Fretting Grease maintains its low-friction properties over an extended period of time, while the competitive OEM-specified products fail prematurely.

Performance for the real world.

As you can see from the figures, our lubricants clearly outperform many competitive products. For instance, figure 1 indicates that Dow Corning® 111 Silicone Compound and Molykote® G-807 Low Friction Silicone Compound withstand high temperatures by nearly 49 percent over another synthetic brake caliper grease, and by 78 percent over a conventional petroleum grease.

Figure 2 indicates that water splash, a tough environmental enemy for brake system components, has minimal effect on our greases. Note that only 66 percent of the petroleum grease is still in place after water spray-off testing, while >97 percent of the lubricant from Dow Corning remains.

Of course, a major requirement for safe braking is corrosion resistance. Again, our lubricants outshine the competition. Figure 3 clearly illustrates this, showing a comparison between European OEM-specified PAGs and Molykote® brand brake caliper greases (silicone and polyalkylene glycol, or PAG, greases).

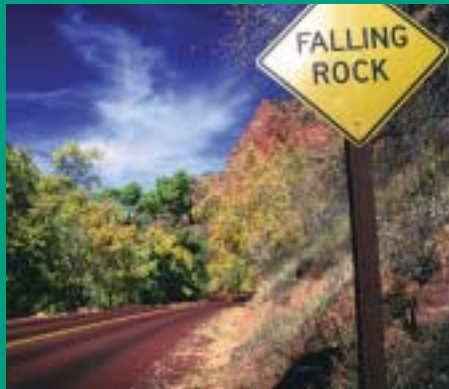

AV07813

A comparison of the low temperature properties of our grease compared with European and Japanese OEM-specified PAGs is illustrated in figure 6. Note that Molykote G-407 Anti-Fretting Grease has both the lowest starting torque and the lowest running torque of any of the tested greases, illustrating it maintains its properties even at low temperatures.

Again and again, tests demonstrate that lubricants from Dow Corning routinely outperform the competition. Curious about how one of our lubricants will hold up in your application? Let's discuss your needs and give you the answer.

Meeting industry standards

While Dow Corning products are approved to meet many OEM and supplier specifications, other approvals may be needed to meet certain requirements. No problem. We can assist you with this testing or, if appropriate, use our facilities to generate the supporting data required for your application.

Salt Spray Comparison
(ASTM B 117, 250 Hours)

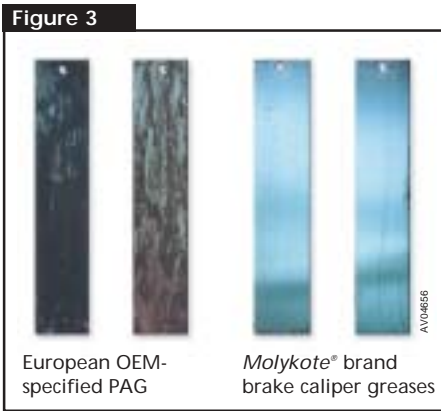

High Temperature Stability Comparison
(Fed-STD-791-321)

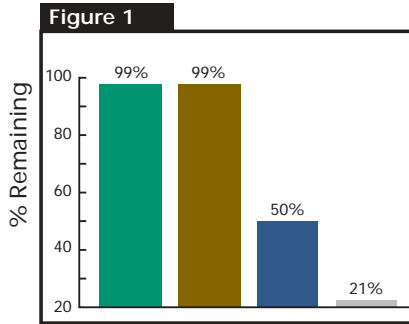

Water Spray-Off Comparison
(ASTM D 4049)

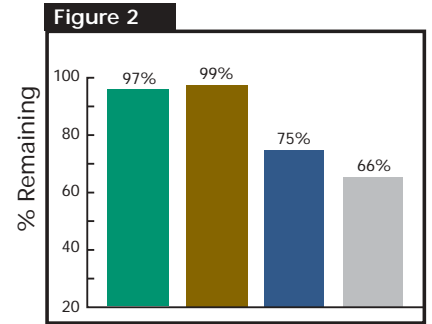

- Dow Corning® 111 Silicone Compound
- Molykote® G-807 Low Friction Silicone Compound
- Other synthetic brake caliper grease
- Conventional petroleum caliper grease

Stiction Comparison

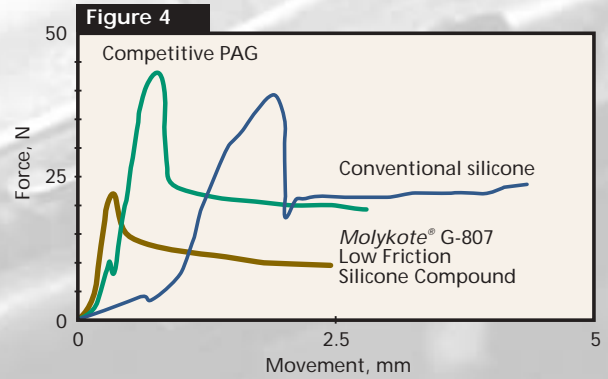

Fretting Comparison
(TE-77 High Frequency Reciprocating [HFR] machine)

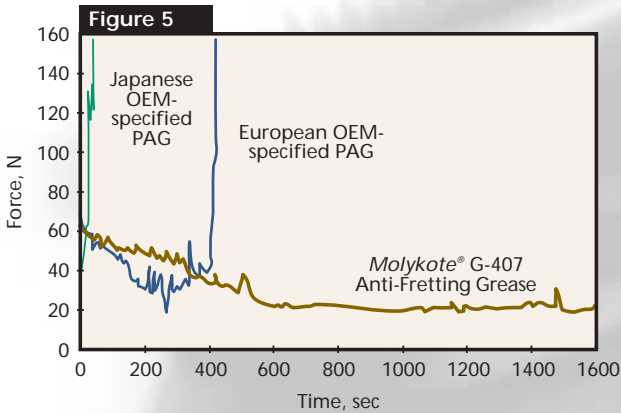

Low Temperature Properties Comparison
(ASTM D 1478 at -20°C)

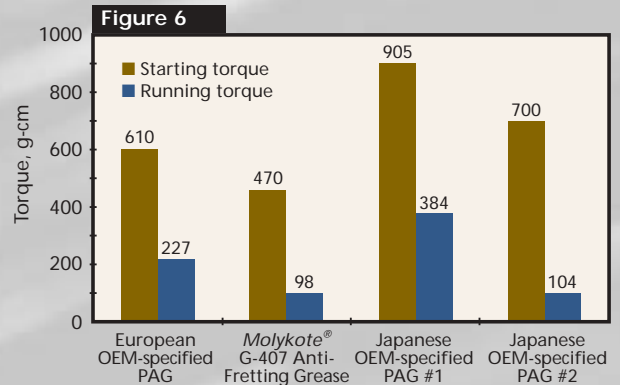



AV04644

A closer look: brake calipers

The metal-to-metal contact of direct-mounted calipers requires synthetic lubricants that can reduce fretting-type wear between the metal surfaces as well as provide good compatibility with rubber seals.

Tests prove that our lubricants provide high resistance to degradation by water and help prevent corrosion. Molykote specialty lubricants resist drying and hardening in high-heat applications offering long service life.

Proper pad, backing plate, and shim lubrication is essential in reducing noise and optimizing brake pad life.

The metal-to-rubber contact of most grommet-mounted calipers requires a silicone-based lubricant that can reduce the stiction between the mounting pin and the rubber without degrading the rubber material.

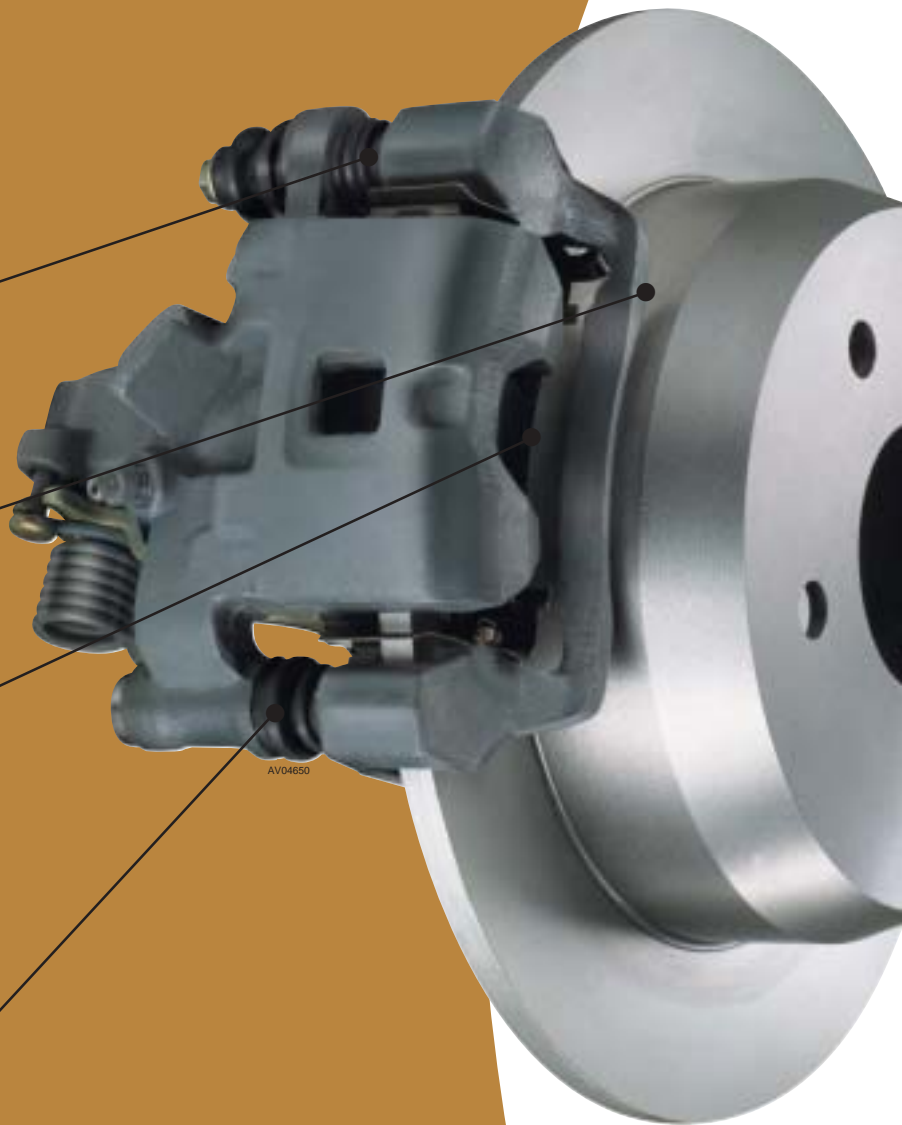

AV04650

Recommended solutions

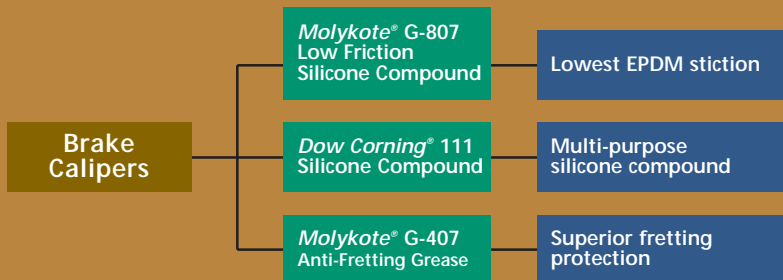

Recommended solutions

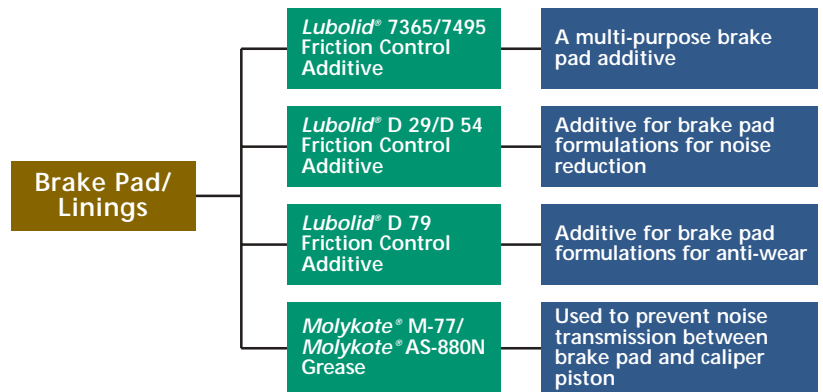

A closer look: brake pad/linings

To isolate transmitted vibration and reduce squeal, apply lubricating paste to the back side of the pads and the backing plates or shims.

Formulated into brake caliper pads and drum brake shoes, friction control lubricants can reduce heat, vibration, and noise.

Our friction control lubricants are environmentally acceptable.



AV04655

A closer look: drum brakes

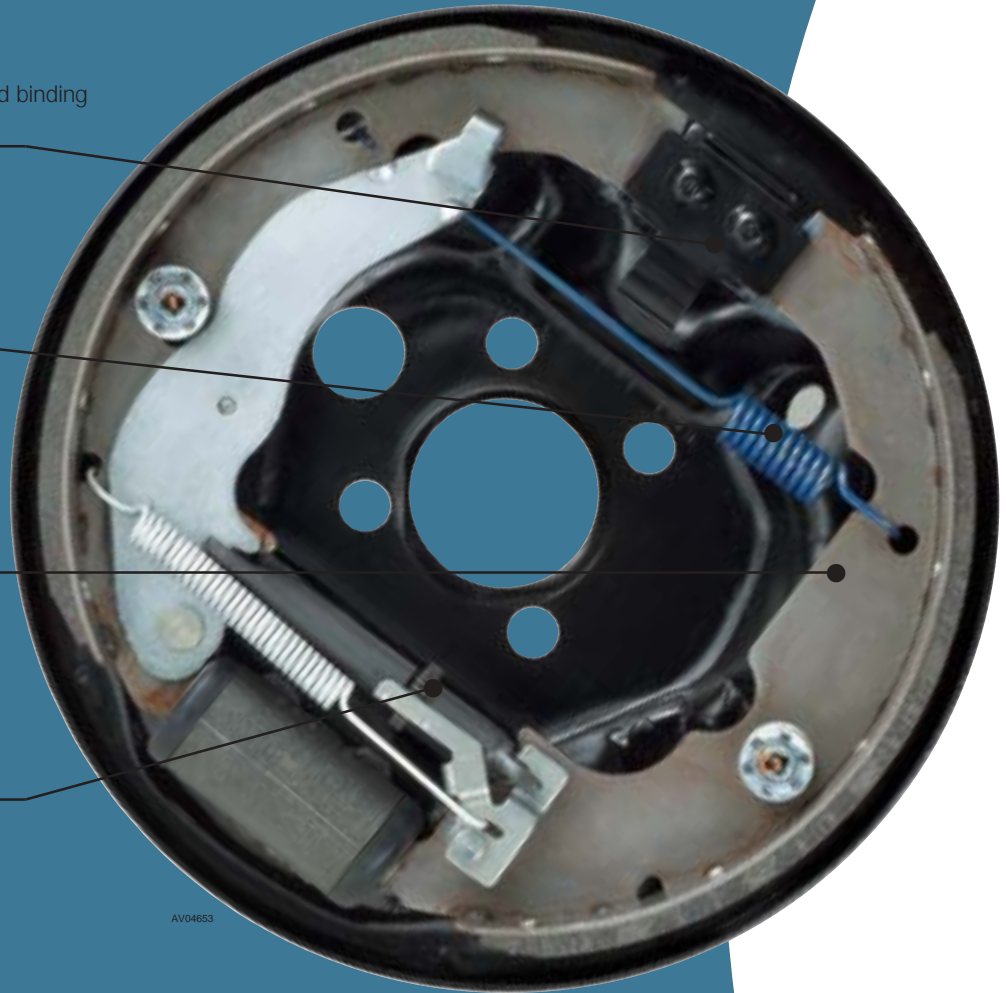

Reduce noise and binding at pivot points.

Reduce return spring noise.

Reduce friction and noise against backing plate.

Eliminate adjusting screw seizure.

AV04653

Recommended solutions

Drum Brakes

Molykote® D 321 R/
Dow Corning® 321
Dry Film Lubricant

Dry film coating does not attract dirt

Molykote® CU 7439 +
High Temperature
Copper Paste

Tenacious copper-fortified paste

Dow Corning® 1000
Anti-Seize Paste

Multi-purpose paste

Dow Corning® G-n
Paste

Lowest friction paste

Recommended solutions

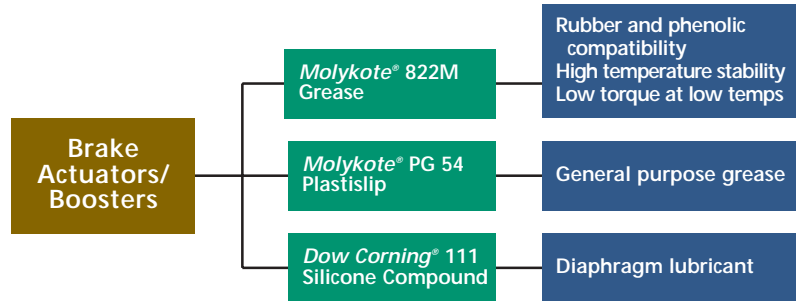

A closer look: brake actuators/boosters

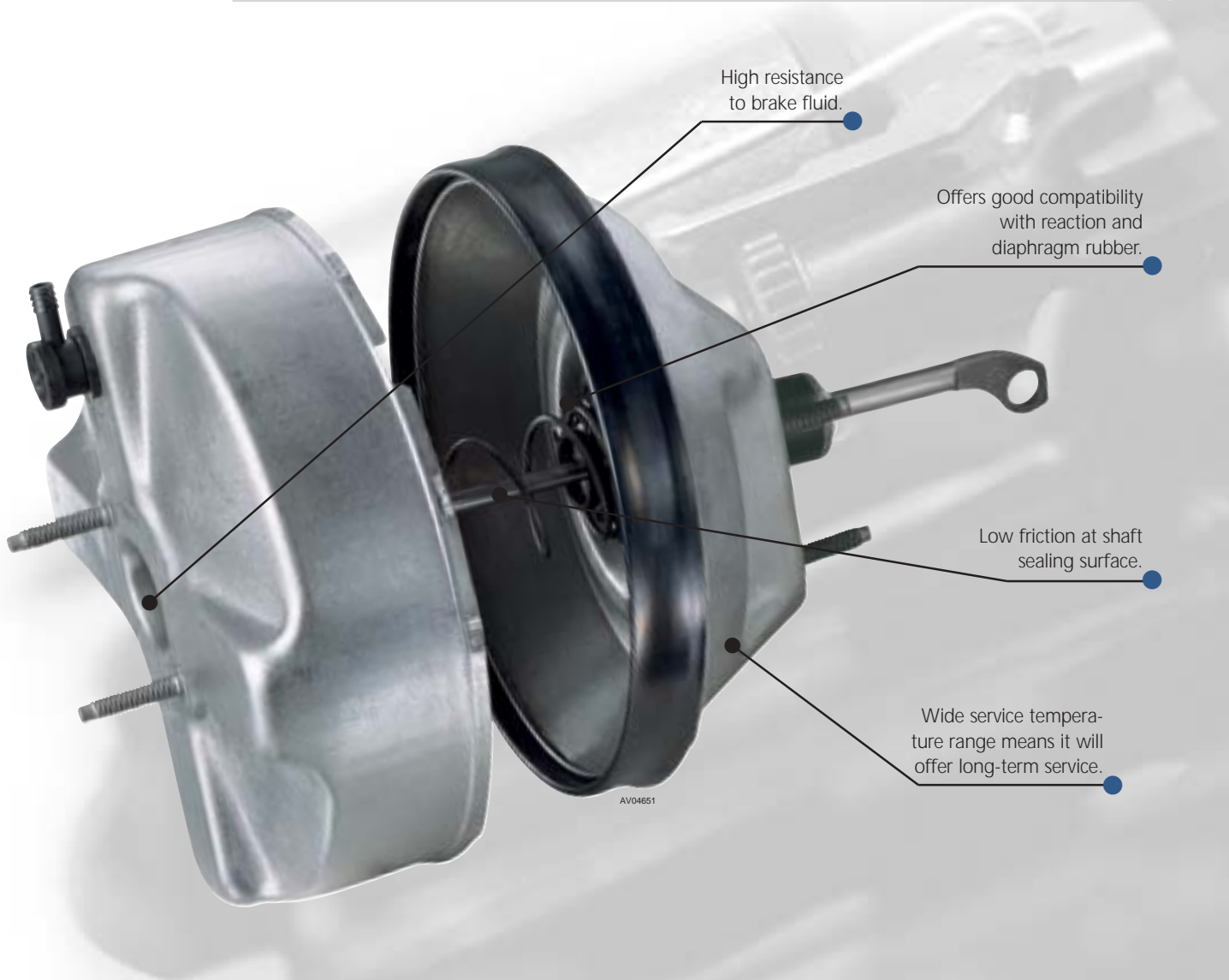

Beyond brakes: multi-technology solutions tackle multiple applications

Innovative materials technology is our greatest strength. It's designed into every one of our lubricants, adhesives, insulating materials, protection materials, sealing and gasketing materials, and torque transfer fluids. And it's backed by a service commitment that means you'll get answers to both design and processing questions.

We invite you to learn more about our multi-technology solutions to your applications by visiting our Web site at www.dowcorning.com/automotive. The site details specific application solutions for:

- body components
- brake systems
- chassis
- electrical components
- electronic components
- engine/drivetrain
- exterior lighting
- fuel systems

The site also leads you through a preliminary selection process to help you discover which of our products might best meet your needs.

To learn more

This brochure and the accompanying data sheets should give you a feel for the types of lubricants that we offer and which one might be best suited to your application. However, it's important that we discuss your needs to ensure that you're getting the best possible product for your application.

Once you're ready to move forward, contact us at www.molykote.com. We'll be glad to discuss your exact needs, provide you with a product sample, and link you with our application development and technical service people, if needed.

Our worldwide automotive centers are strategically located to meet your global demands. Whether you require global support for product development, application engineering, commercial supply, or manufacturing services, we're well positioned to help. Just ask.



AV09647



AV04643



How To Contact Us

For nearly 60 years, OEM designers, maintenance and materials engineers around the world have trusted the Molykote brand for performance and expertise to solve or prevent lubrication problems. Molykote solutions are available through a distributor network of more than 3,000 channel partners around the globe. To learn more about our extensive product and service offering, visit www.molykote.com, or email industrial@dowcorning.com.

LIMITED WARRANTY INFORMATION – PLEASE READ CAREFULLY

The information contained herein is offered in good faith and is believed to be accurate. However, because conditions and methods of use of our products are beyond our control, this information should not be used in substitution for customer's tests to ensure that Dow Corning's products are safe, effective, and fully satisfactory for the intended end use. Suggestions of use shall not be taken as inducements to infringe any patent.

Dow Corning's sole warranty is that the product will meet the Dow Corning sales specifications in effect at the time of shipment.

Your exclusive remedy for breach of such warranty is limited to refund of purchase price or replacement of any product shown to be other than as warranted.

DOW CORNING SPECIFICALLY DISCLAIMS ANY OTHER EXPRESS OR IMPLIED WARRANTY OF FITNESS FOR A PARTICULAR PURPOSE OR MERCHANTABILITY.

DOW CORNING DISCLAIMS LIABILITY FOR ANY INCIDENTAL OR CONSEQUENTIAL DAMAGES.

We help you invent the future is a trademark of Dow Corning Corporation.

Dow Corning, Lubolid and Molykote are registered trademarks of Dow Corning Corporation.

©2004 Dow Corning Corporation. All rights reserved.

Form No. 10-9431A-01

DOW CORNING

*We help you
invent the future.™*

www.dowcorning.com

Maahantuoja:

 **YTM-Industrial**
INDUTRADE GROUP

Petikontie 20, 01720 Vantaa
Puh. 029 006 230, fax. 029 006 1230
www.ytm.fi, e-mail ytm.info@ytm.fi

Jälleenmyyjä: